

Up to 6kW (One Phase)

Also for 2 x 127V (2°)
for Latin America

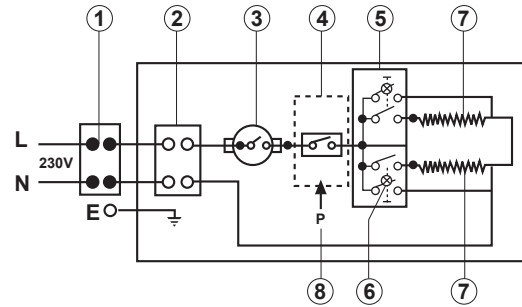

7kW to 9.5kW (One Phase)

Also for
127V up to 5kW

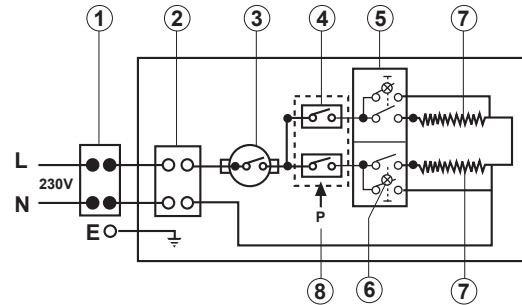

5.5kW to 9.5kW (Two Phase)

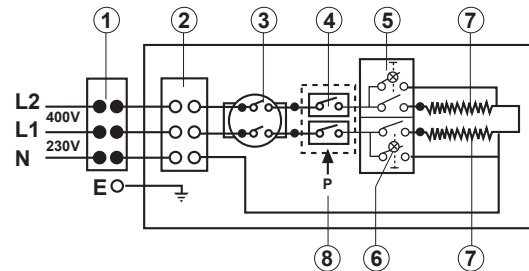

- | | |
|----------------------|---------------------|
| 1. Multi-pole switch | 5. Switches |
| 2. Terminal block | 6. LED Light |
| 3. Thermostat | 7. Heating elements |
| 4. Microswitch | 8. Pressure switch |

Table 2

Model	Heat Setting	kW loading			Recommended cable size	Recommended fuse rating
		220V	230V	240V		
New/Lotus - 3.0	1.0;2.0 or 3.0kW	3.0	3.3	3.6	2.5mm ²	16amps
New/Lotus - 3.5	1.5;2.0 or 3.5kW	3.2	3.5	3.8	2.5/4mm ²	20amps
New/Lotus - 5.0	2.0;3.0 or 5.0kW	5.0	5.5	6.0	4/6mm ²	25amps
New/Lotus - 5.5	2.5;3.0 or 5.5kW	5.5	6.0	6.6	4/6mm ²	25-32amps
New/Lotus - 7.0	3.0;4.0 or 7.0kW	7.0	7.7	8.3	6/10mm ²	40amps
New/Lotus - 8.0	4.0;4.0 or 8.0kW	7.3	8.0	8.7	6/10mm ²	40amps
New/Lotus - 9.5	4.5;5.0 or 9.5kW	8.7	9.5	10.3	10mm ²	45amps

• Operating water pressure 0.3-7 BAR (5-100 psi) • Water pressure operating power switch
• Standard 1/2"Ø compression inlet connection • Top-left and right cable entry • Bottom-left water entry

UNIT DIMENSIONS: HEIGHT 185mm WIDTH 300mm DEPTH 110mm

INSTANT WATER HEATER

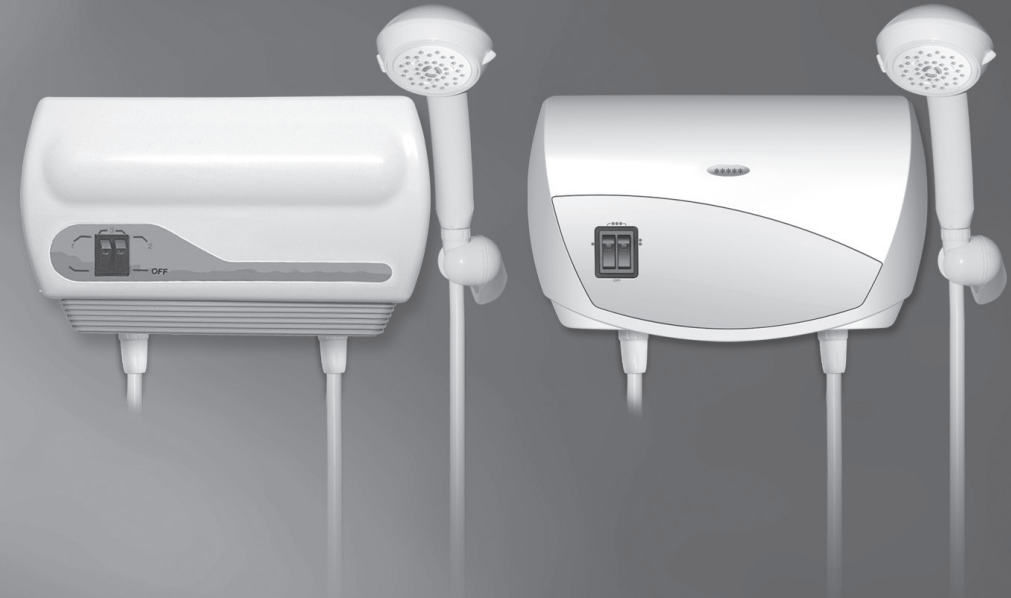

P.N: 116002B

■ ■ ■ ■ Installation Instructions ■ ■ ■ ■

Installation Instructions:

THE GUARANTEE IS SUBJECT TO CORRECT INSTALLATION.

The instant water heater is a novel appliance designed to supply hot water instantly while conserving energy. When the pressure switch is on, then the heating element heats the flowing water.

General information

1. The appliance should be installed by a licensed electrician only.
2. It is recommended that a residual current device (ELCB) will be incorporated in the circuit.
3. Installation of water pipeline must be completed prior to the installation of the heater and must be checked to assure that there are no water leaks.
4. This appliance requires water pressure of minimum 0.3 bar (4LB /IN). The appliance must be installed horizontally where water supply comes from the left side.
5. **WARNING! You must use only the supplied outlet accessories. The water outlet should always be left open as the operating principle is based on an open water outlet.**
6. Without supervision the use of the appliance by young children or infirm person is forbidden. Playing with the unit by young children is forbidden.

Installation of sink & shower unit 3 kW - 9.5 kW

1. The shower unit should be installed above a person's height. (use installation chart)
2. Remove cover in order to connect the electric cable to the terminal block inside the unit. (unscrew 4 screws)
3. The unit should have a separate electric cable in the switch board (see table 2)
4. The recommended electric cable for 2-Phase unit up to 9.5kW is 5 x 4.0mm²
5. A 110V/5kW device must be connected to a separate 40A fuse and a feeding cable of 3X6 mm².
6. Check if there are no leaks as soon as the unit is connected. Use the hoses supplied with the appliance, do not re-use old hoses
7. After connecting the water inlet to the unit, connect the electric cable to the designed terminal blocks including grounding. **WARNING! The appliance must be grounded**
8. The unit must be connected to the electric supply by a 2-pole switch (for one phase unit) and to the multi-pole switch (in case of multi phase unit)
9. The main electric switch should be separated from the unit.
10. Connect the electric cable with the designated clamp.
11. Return the cover (4 screws)

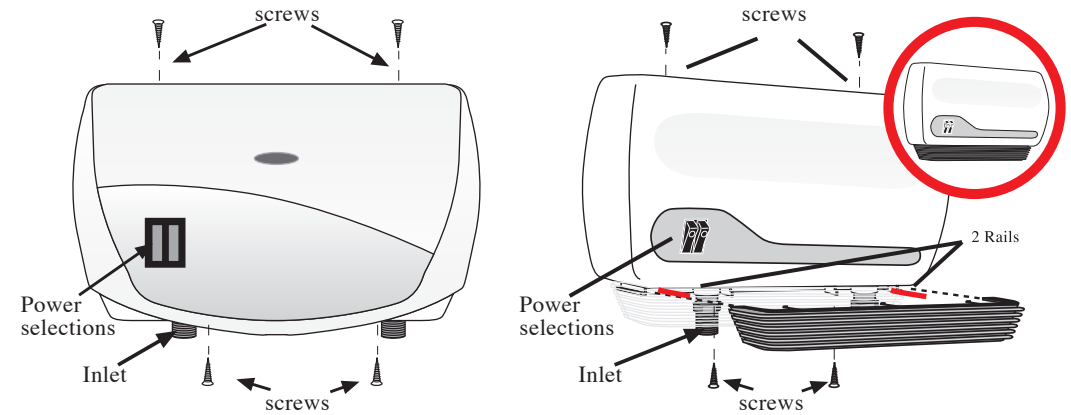
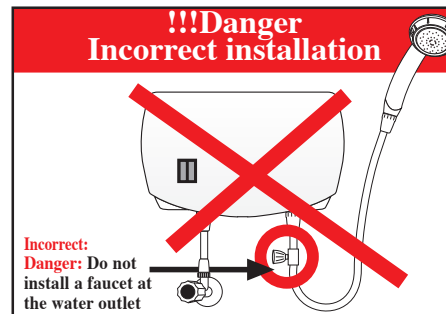
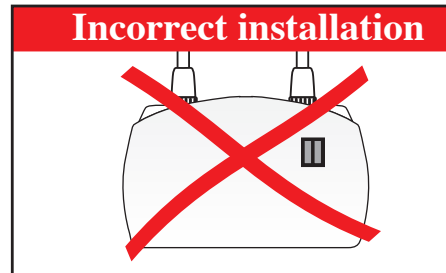
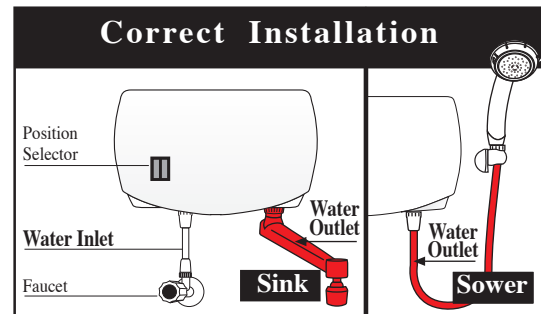

For effective use

1. Open the water faucet (before inlet) slowly until the lights in the rocker switch are "ON". Wait 15-20 seconds until hot water starts to flow. For colder water increase the water inflow gradually until you receive the desired water temperature. For hotter water please decrease water inflow.
2. Heating position selector:
 - 0 - Shut Off
 - 1 - Low (left light on)
 - 2 - Medium (Right light on)
 - 3 - High (both lights on)
3. In order to achieve maximum efficiency from the unit please grip the showerhead and twist it in either direction, operating rings installed in showerhead can be changed according to season, summer or winter position (Fig.1 & Fig.2). An additional ring set is supplied with the unit for head set 1 (Fig.1a).
4. For sink unit - Install open rings in summer and blind rings in winter (inner ring should remain always open) (Fig.3).
5. The unit operates automatically by opening the water faucet and shut off when closing the water supply.

